



SUBARU

INSTALLATION INSTRUCTIONS

PART NUMBER: L101SXC002

DESCRIPTION: 2019 ASCENT TRAILER HITCH

PLEASE READ THIS INSTRUCTIONS CAREFULLY, BEFORE YOU START INSTALLATION

SAFETY PRECAUTION: When installing Trailer Hitch, the use of safety glasses is recommended.

WARNING:







1. Always install the accessory following the instructions. Failure to do so may cause damage to the vehicle or the accessory.
2. Please also refer to SUBARU SERVICE MANUAL upon removing and re-assembling vehicle components.
3. Do not drill, cut, weld or otherwise modify the Trailer Hitch.
4. Do not lubricate the bolts and nuts with oil or grease.
5. If Trailer Hitch is removed, a bumper beam **MUST** be reinstalled. Failure to reinstall a bumper beam after removal of the trailer hitch will negatively affect vehicle rear crash performance. Please contact your SUBARU dealer.
6. When a Trailer Hitch is installed, it is not possible to install the rear towing hook.
7. Never exceed the maximum towing capacity and maximum tongue load. It could cause personal injury and/or vehicle damage.
8. When towing, total vehicle weight must not exceed the Gross Vehicle Weight Rating (GVWR). Also the load distribution on each axle must not exceed the Gross Axle Weight Rating (GAWR). The GVWR and GAWR for your vehicle can be found on the "Certification label" which is located on the left side center pillar of the vehicle.
9. For models equipped with RAB, refer to the part which indicated [RAB].
10. Ensure all recyclable discarded vehicle accessory components and packaging are recycled following local recycling regulations.
11. It is always recommended that this accessory is fitted by a qualified SUBARU technician.
12. In the engine bay, disconnect the negative battery terminal.
13. Safely store and protect any removed vehicle components.
14. Ensure all bare metal surfaces are protected using Automotive Bare Metal Primer and touch-up paint.
15. Remove all metal swarf and dust from all vehicle surfaces if surface is used for accessory installation.

Warranty is granted only when installation is done correctly by your SUBARU dealer.

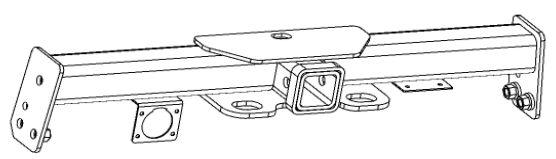
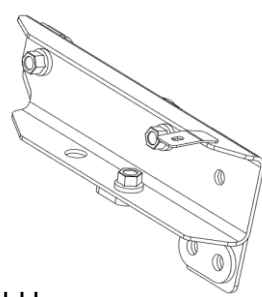
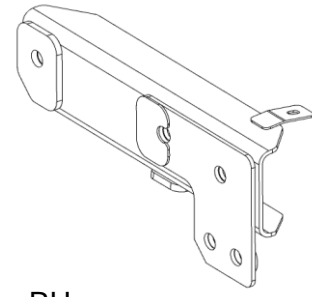
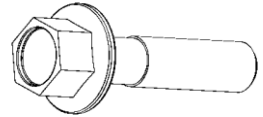
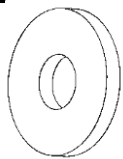
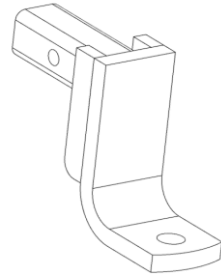
SUBARU reserves the right to change the design of accessories and/or construction, illustration, and text of this manual at anytime without prior notice.

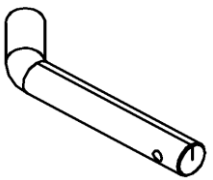
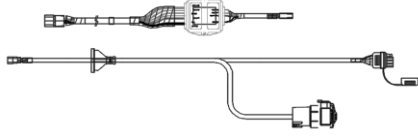
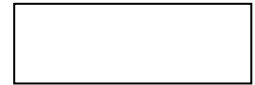
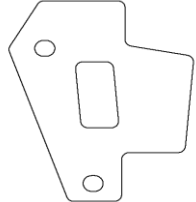
Please put installation instruction in glove box once installation is complete.

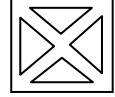
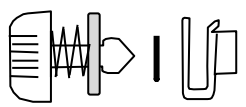
KIT CONTENTS:

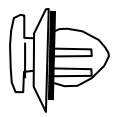
<p>A</p>  <p>x1</p>	<p>B</p>  <p>LH x1</p>	<p>C</p>  <p>RH x1</p>	
<p>D</p>  <p>M14 hex flange bolt x12</p>	<p>E</p>  <p>flat washer x8</p>	<p>F</p> 	<p>G</p> 
<p>H</p>  <p>x1</p>	<p>I</p>  <p>wiring harness x1</p>	<p>J</p>  <p>foam tape x2</p>	
<p>K</p>  <p>cover panel x2</p>	<p>L</p>  <p>cable tie x11</p>	<p>M</p>  <p>cable tie mount x9</p>	
<p>N</p>  <p>1/4 turn fastener assembly x2</p>	<p>O</p>  <p>brake controller pigtail x1</p>	<p>P</p>  <p>tail light cover panel clip x4</p>	

TOOLS REQUIRED:

1/2" and/or 3/8" drive torque wrench(es)
(capable of measuring 82 ft-lb and 5 in-lb)

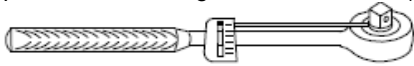

7mm socket



1/2" and 3/8" drive ratchet

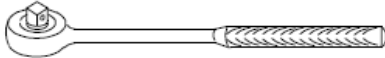

Needle nose pliers

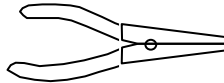

Flat head screwdriver



6" socket extension

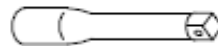

Phillips head screwdriver



touch up paint



7 mm open end wrench

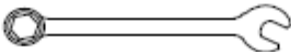

side cutter

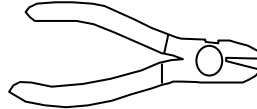

3/8" open end wrench

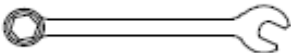

sandpaper or scouring pad (Scotch Brite)



19mm deep well socket



17mm deep well socket

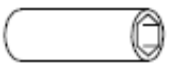

14mm deep well socket

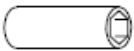

10mm socket



1 REMOVE REAR PANEL AND LOWER SPARE TIRE

- ① Raise and remove the carpeted rear floorboard

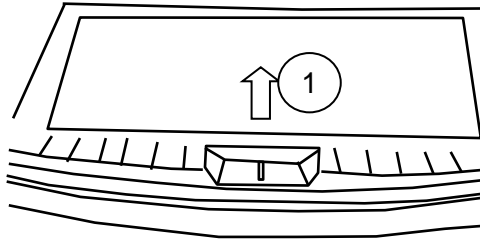

- ② Remove the square panel and rubber grommet to access the spare tire winch

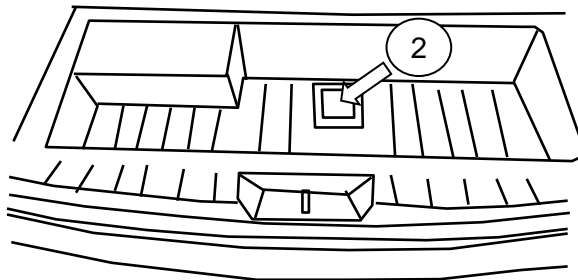

- ③ Use the spare tire wrench to turn the winch and lower the spare tire

remove cover to
access tools

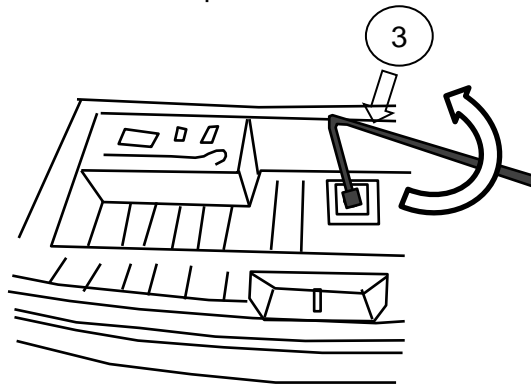
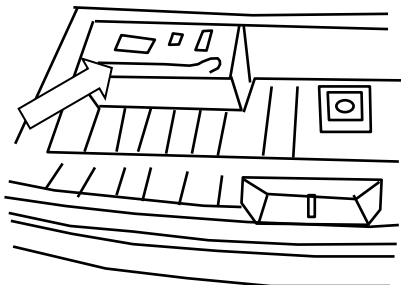

- ④ Lower the spare tire to the ground.

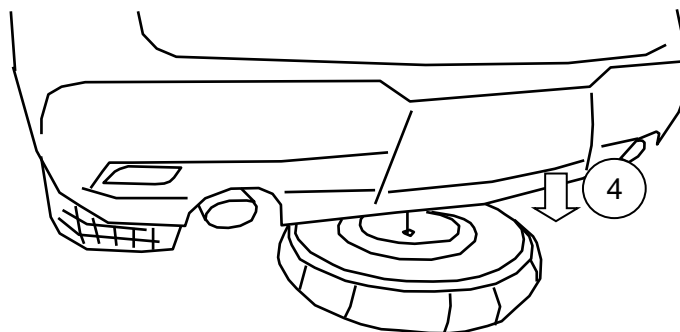

2 REMOVE REAR BUMPER FASCIA

- ① Remove the rear tail light cover (LH and RH sides) by pulling back to release 2 clips and then up to remove hook.

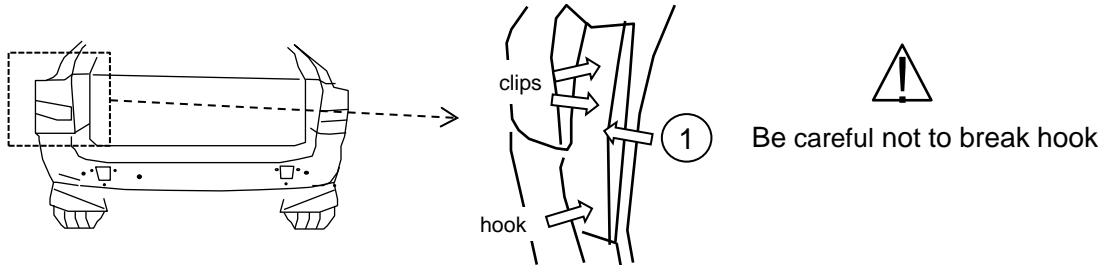

- ② Remove 2 clips per side from the inside of the tail light cover by sliding them out. Replace the clips with 2 new clips "P". Install the new clips by sliding them in until they are fully seated.

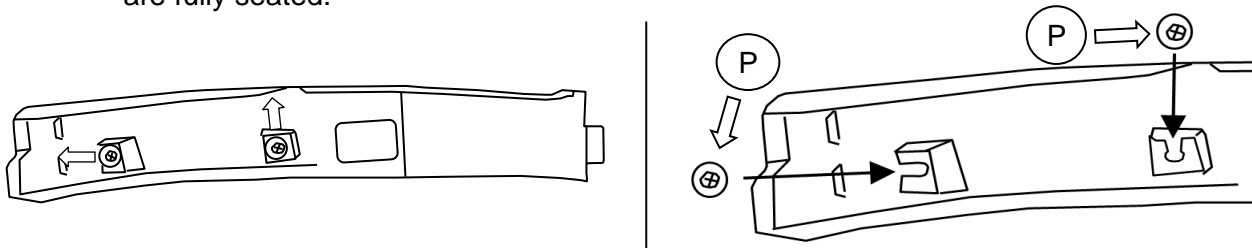

- ③ Remove M6 screws from bumper fascia (LH and RH sides)

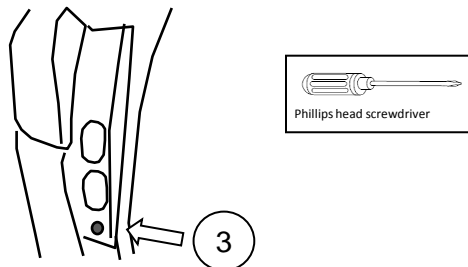

- ④ With a screwdriver, release (1) small push pin fastener per side on the LH/RH fascia wheel well. Use the tip of the screwdriver to push the center of the pin.

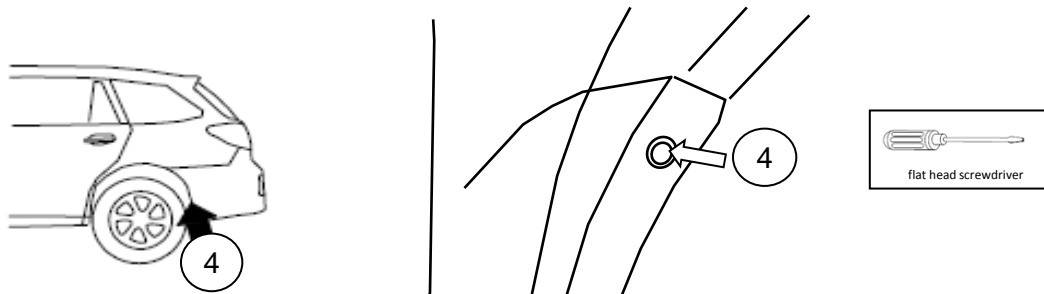

- ⑤ Carefully set aside the fasteners and components where they will not be damaged. Parts will be reinstalled later.

2 REMOVE REAR BUMPER FASCIA (CONTINUED)

- ⑥ With a small flat head screwdriver, remove (6) large push pin fasteners across the length of the bumper. Save push pins for later use.

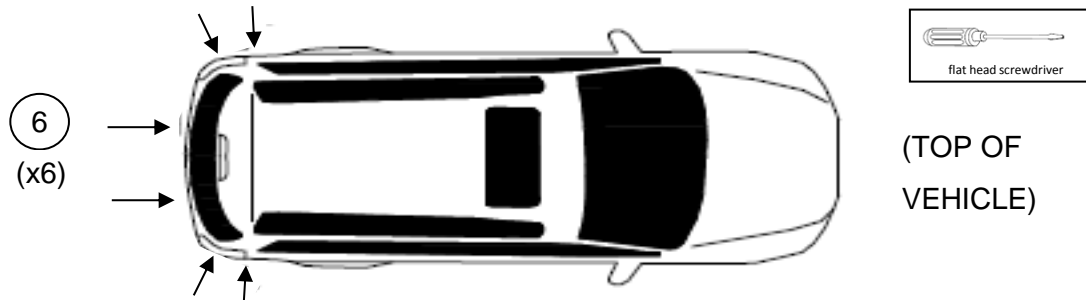

- ⑦ Starting at the LH side wheel well, using both hands, pull one side of the fascia out from the vehicle.

- ⑧ Continue around the rear LH side. At the rear corner, begin to pull rearward and work across halfway across the vehicle.

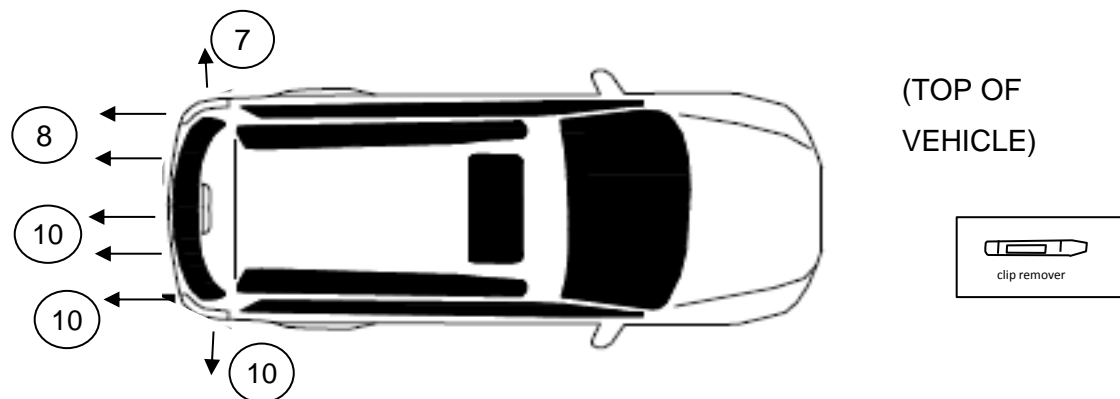

- ⑨ Disconnect the RAB sensor harness connector at the LH side of the bumper beam.

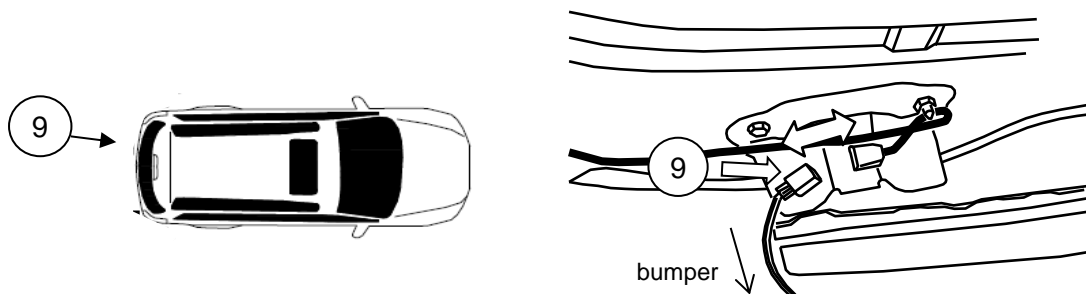

- ⑩ Continue across the rear and work across the vehicle to remove the entire bumper.
- ⑪ Fully release the bumper from the vehicle body.
- ⑫ Lay fascia aside where it will not be damaged during hitch installation.

3 REMOVE REAR BUMPER BEAM

- 1 Remove the foam piece.
- 2 Disconnect and remove the RAB harness connector (a) and the smart antenna connector (b) from the top of the bumper beam on LH and RH sides.

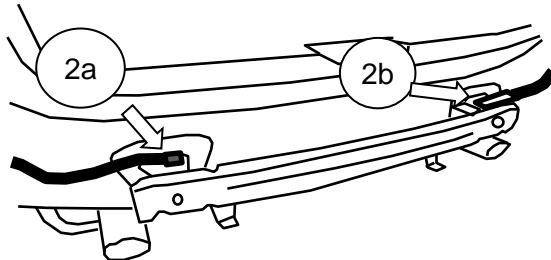

 Be careful not to damage connectors or wiring harnesses.



- 3 Using 17 mm deep socket, remove (3) bolts and (1) nut from each side of the bumper beam.

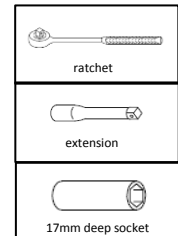
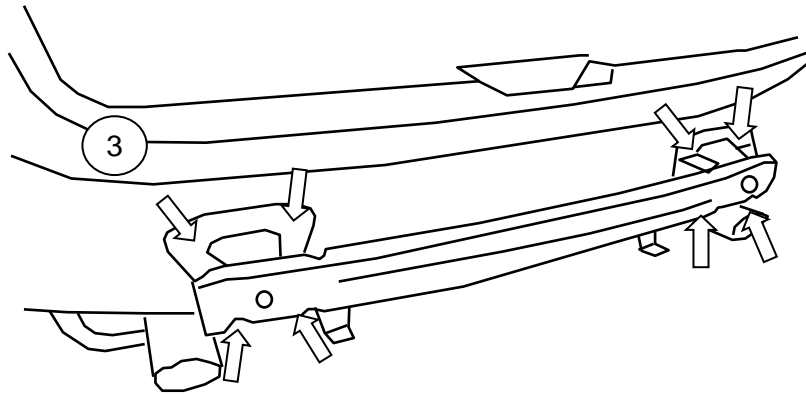

- 4 Retain (4) of the bolts for installation of cover panel.
- 5 Remove the bumper beam.
 -  If Trailer Hitch is removed, a bumper beam **MUST** be reinstalled. Failure to reinstall a bumper beam after removal of the trailer hitch will negatively affect vehicle rear crash performance. Please contact your SUBARU dealer.
- 6 Reinstall (1) nuts and (1) bolts on each side in the location shown.
- 7 Apply touch up paint on the bare metal areas around the bolts to avoid corrosion.

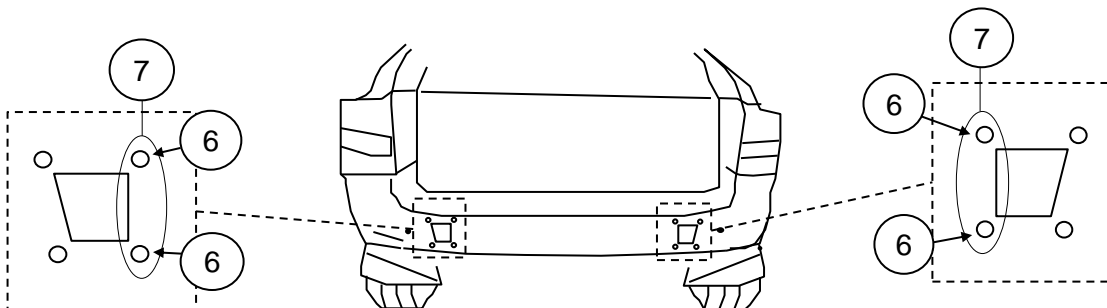

4 INSTALL LH / RH FRAME BRACKET ASSEMBLIES - PARTS "B" & "C"

- 1 Remove (1) rubber grommets (a) and (2) adhesive patches (b) per side from the bottom of the side frame.
- 2 Place LH welded bracket assembly "B" into side frame hole opening.

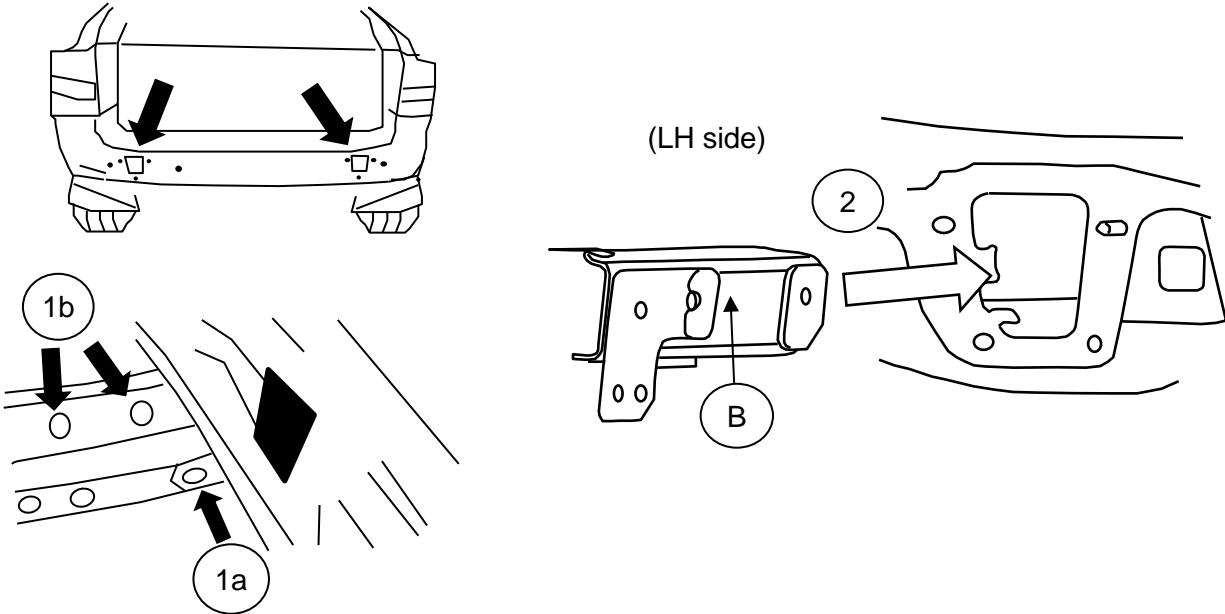

- 3 Align the bracket holes with the holes in the frame rail.
- 4 Loosely install (3) M14 bolts "D" and washers "E" first through the (1) bottom frame hole followed by the (2) side frame holes.

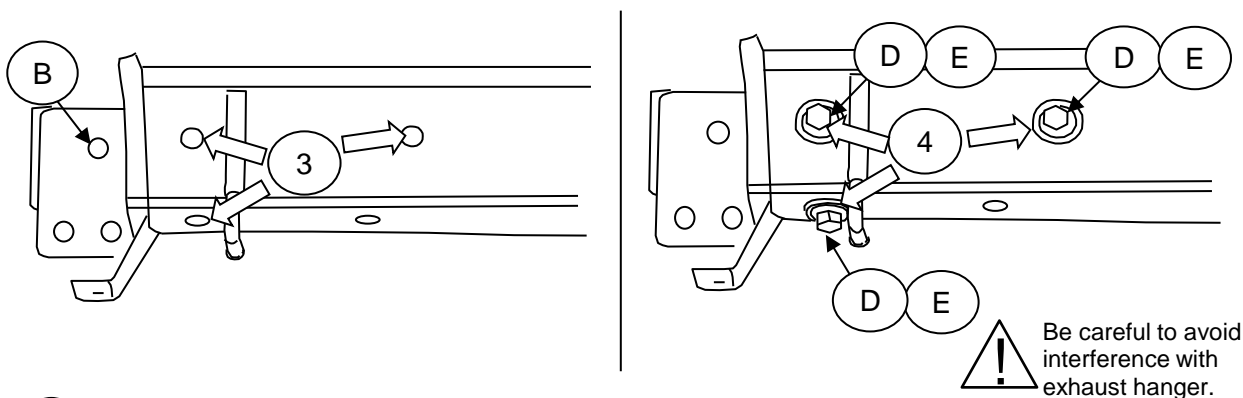

- 5 Repeat steps #2-4 for the RH side bracket assembly "C".

- ⑥ If already connected, separate the 7-pin connector from the wiring harness "I" by pressing down on the latch to release.

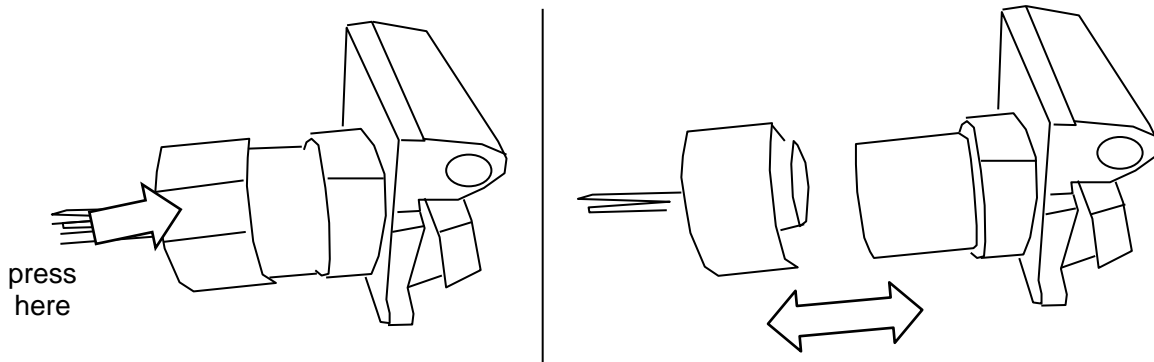

- ⑦ Drape the wiring harness from Step 4-6 across the LH bracket as shown.

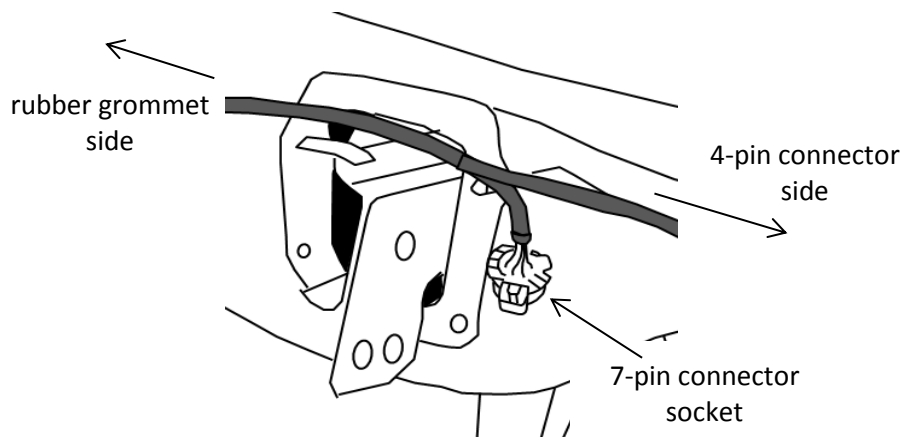

5 INSTALL MAIN HITCH MEMBER - PART "A"

- ① Apply 4 cable tie mounts "M" to the bottom of the hitch chain plate and cross tube in the locations shown below.
NOTE: Clean the surface before applying adhesive.

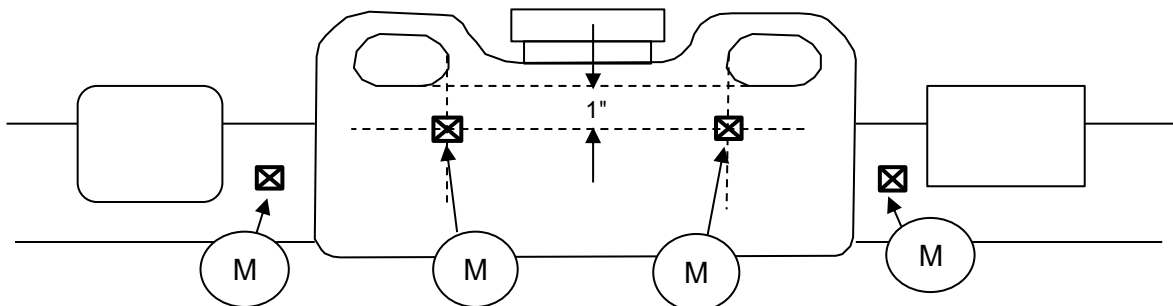

5 INSTALL MAIN HITCH MEMBER - PART "A" (CONT'D)

- 1 Install the main hitch "A" between the LH and RH frame bracket assemblies "B" and "C". Be sure that the wiring harness is located between the hitch and vehicle but not pinched in place.

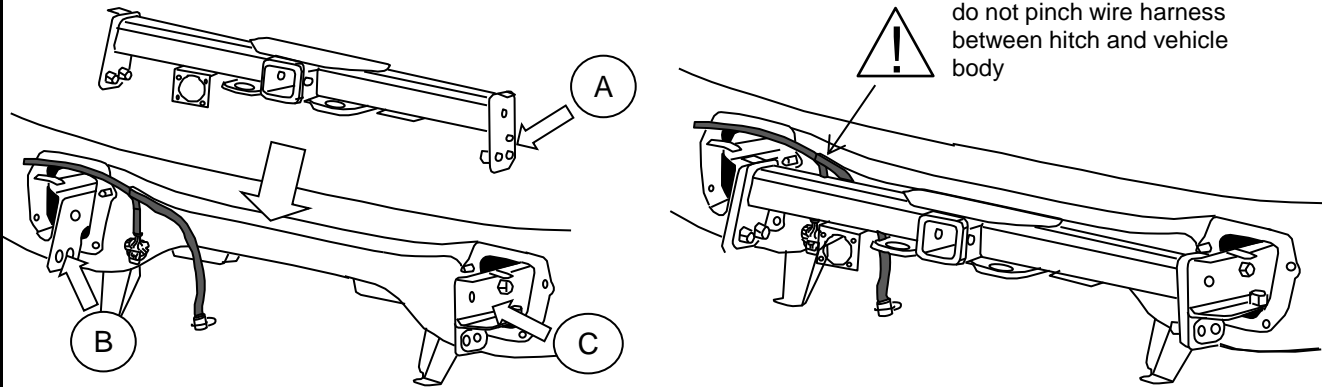

- 2 Loosely install (1) M14 bolt "D" and washer "E" and on each side through the top hole in LH/RH bracket assemblies "2" and "3".

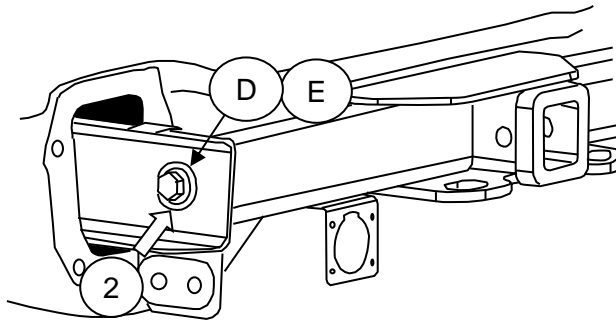

- 3 Loosely install (2) M14 bolts "D" on each side through the bottom holes in bracket assemblies "1" and "2".

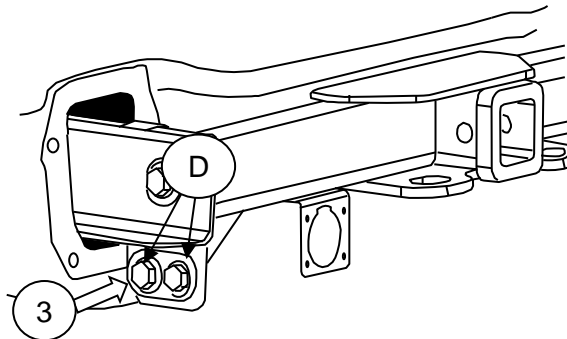

- 4 Hand tighten all (6) M14 bolts on each side

6 INSTALL COVER PANEL "M"

- 1 Using the (4) bolts saved in Step 3-4, install (1) panel cover "K" per side into the frame weld nuts

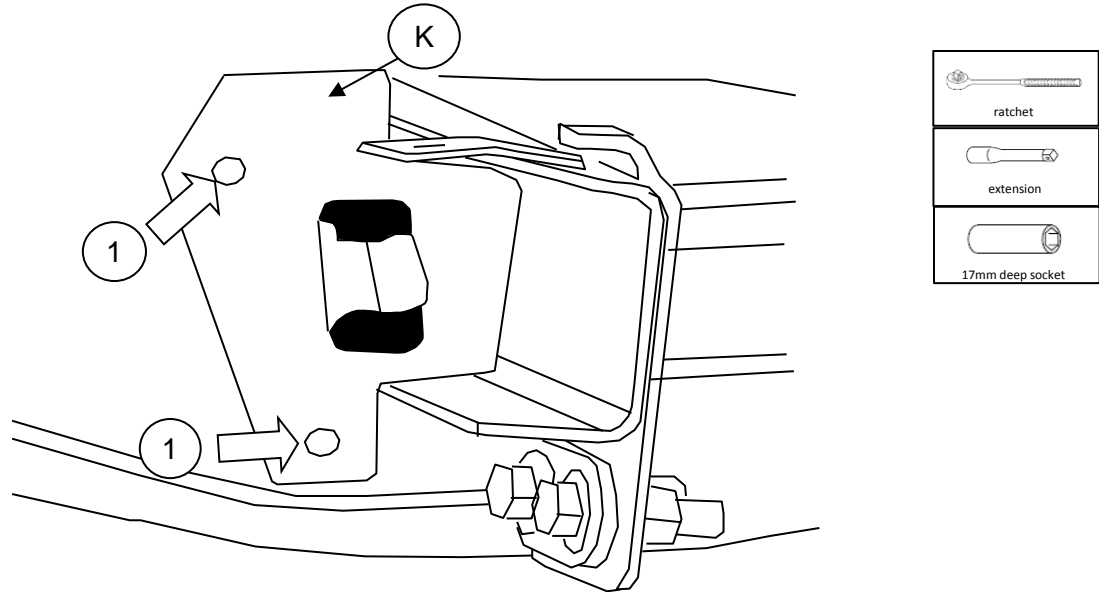

7 RECONNECT RAB SENSOR HARNESS & ANTENNA CONNECTORS

- 1 Reinstall the RAB (a) and smart antenna (b) connectors removed in Step 3 - 2 into the tabs in the hitch bracket assemblies "2" and "3"

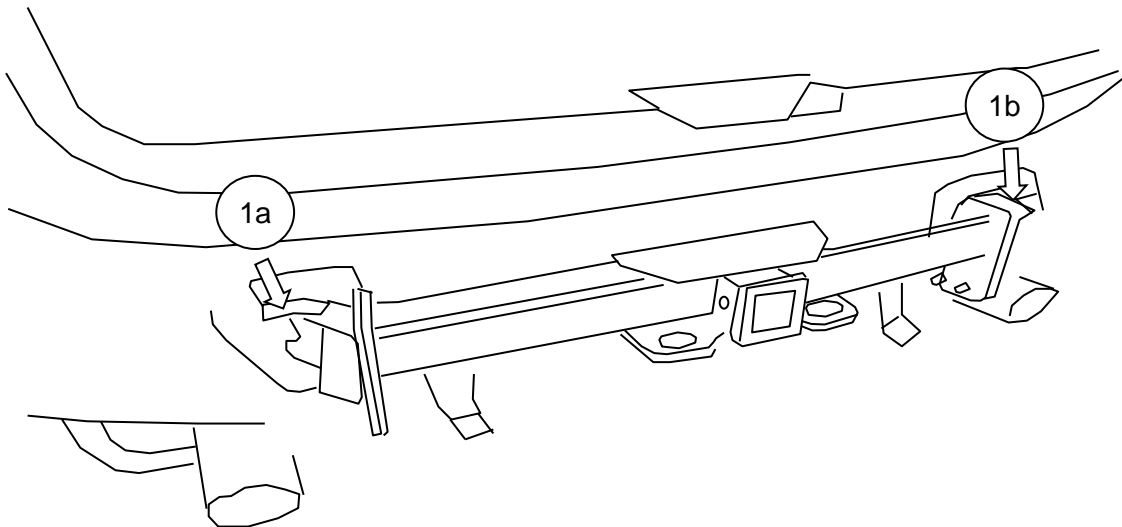

8 TORQUE FASTENERS



1 Torque all fasteners in the order and to the torque values as shown in the table

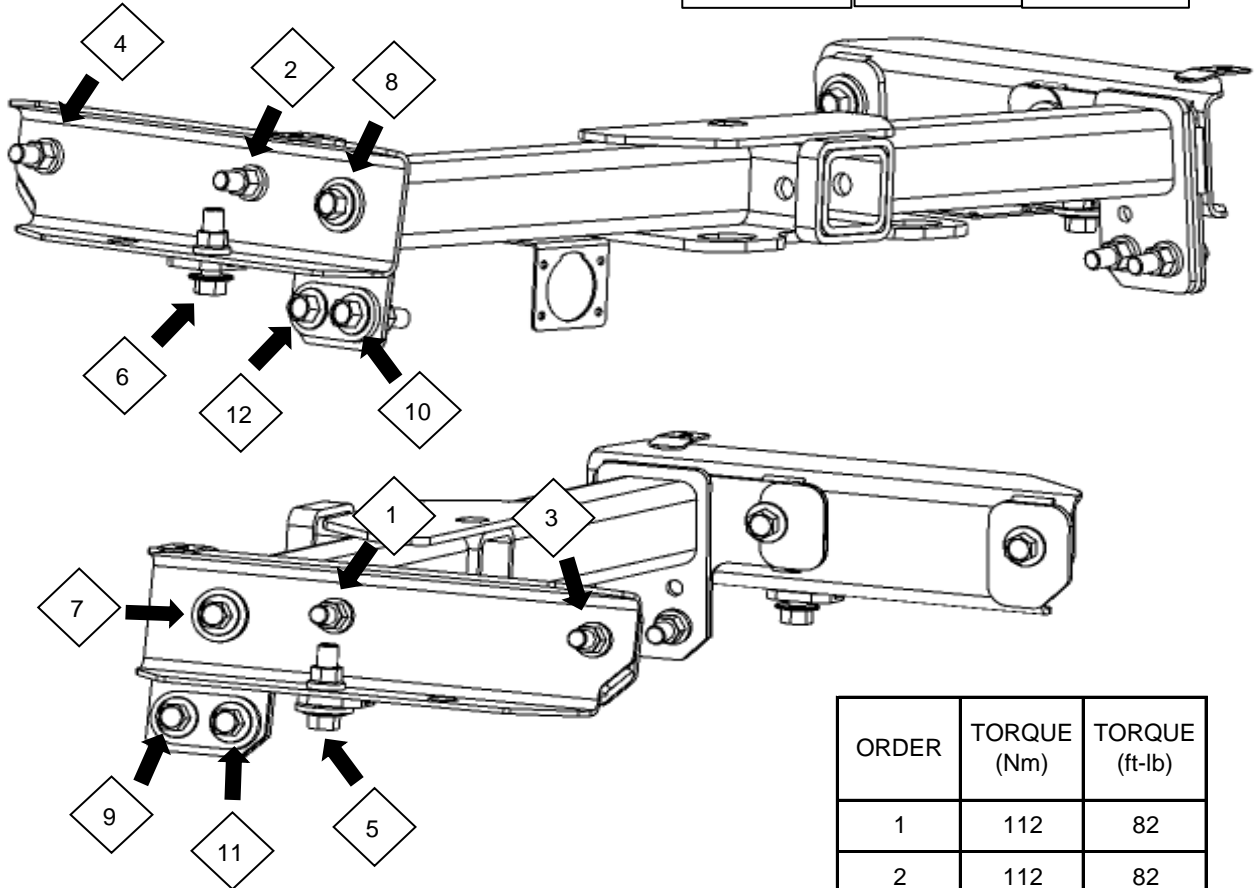
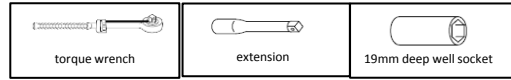

ORDER	TORQUE (Nm)	TORQUE (ft-lb)
1	112	82
2	112	82
3	112	82
4	112	82
5	112	82
6	112	82
7	112	82
8	112	82
9	112	82
10	112	82
11	112	82
12	112	82

9 WIRING HARNESS INSTALLATION

- 1 Using 4 nuts, bolts, and washers (included in wiring harness kit) mount the 7-pin connector housing to the tow hitch bracket. (the hardware may be located inside the connector housing under the flip-up cover)

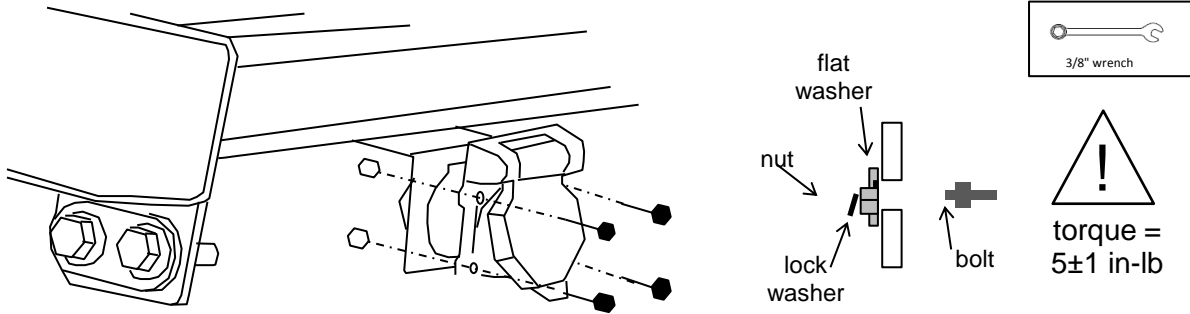

- 2 Install the 4-pin connector into the wiring harness mounting bracket on the tow hitch using the clamp bracket and hardware included in the wiring harness kit. Then plug the 7-pin connector socket into the back of the 7-pin connector

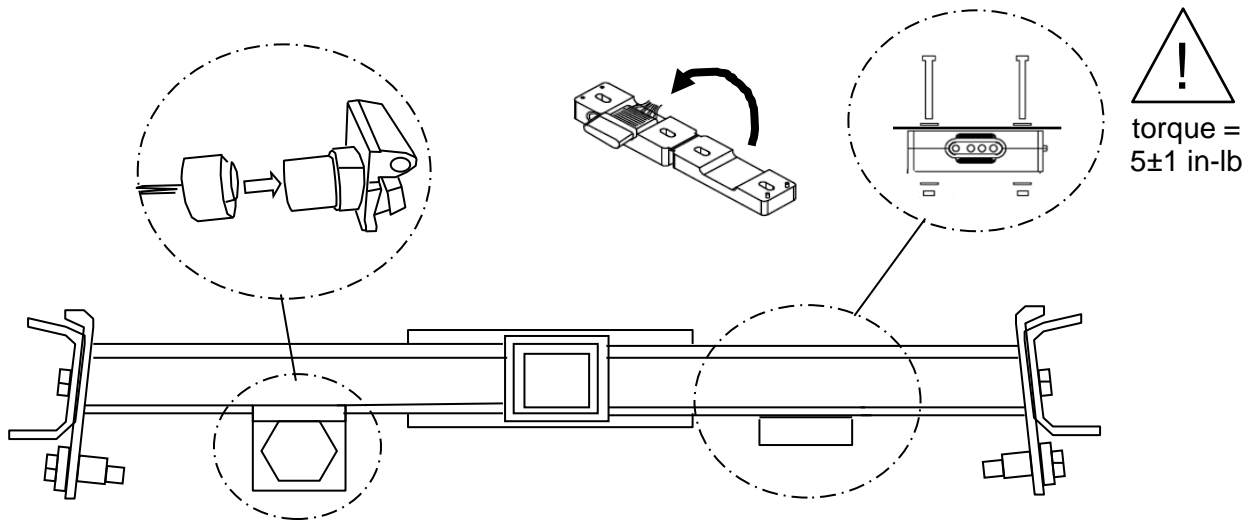

- 3 Run the wiring harness across the bottom length of the hitch tube and route it behind the tube at the LH bracket location.

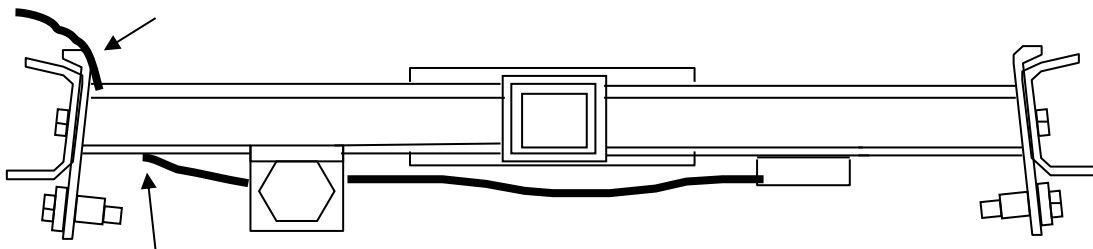

9 WIRING HARNESS INSTALLATION (CONTINUED)

- ④ Secure the wiring harness to the mounts using the remaining cable ties "L". Trim off the excess tail of the cable ties.

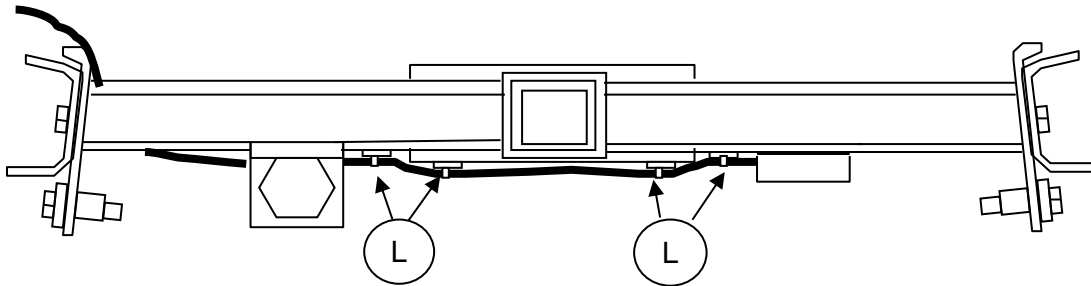
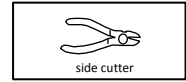

- ⑤ Apply a cable tie mount "M" behind the hitch tube to the rear vehicle body panel in the 2 location as shown below. Clean the vehicle surface before applying the adhesive mount.

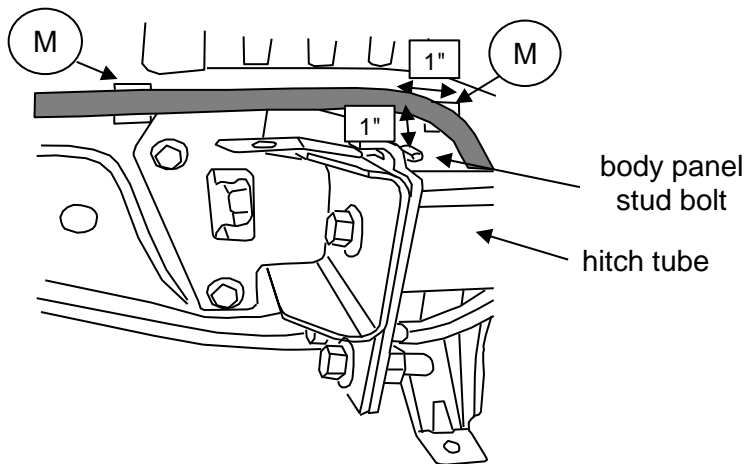

- ⑥ Continue to route the wiring harness towards the rear LH corner of the vehicle. Route the harness behind the bracket, RAB module, and wiring.

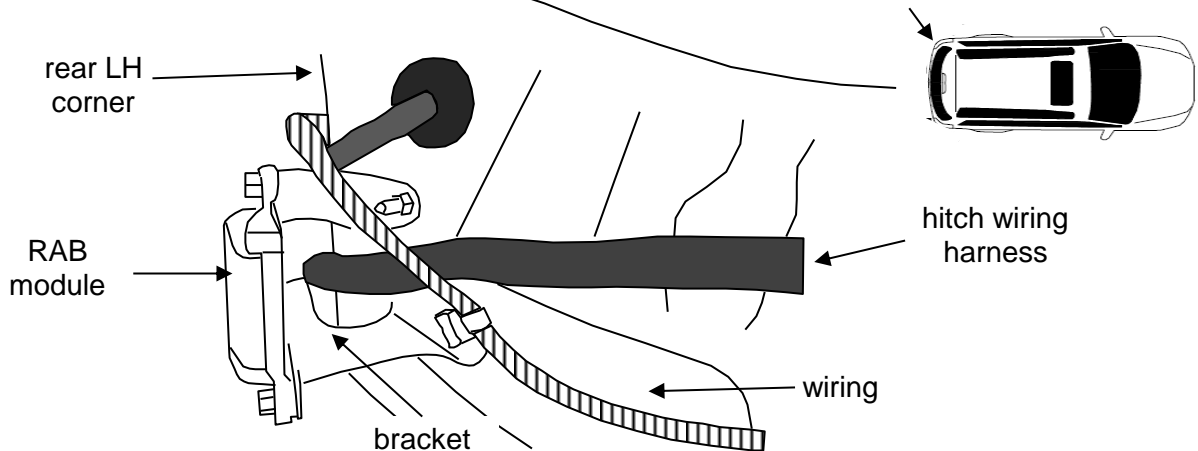

9 WIRING HARNESS INSTALLATION (CONTINUED)

7 Remove rear cargo tray.

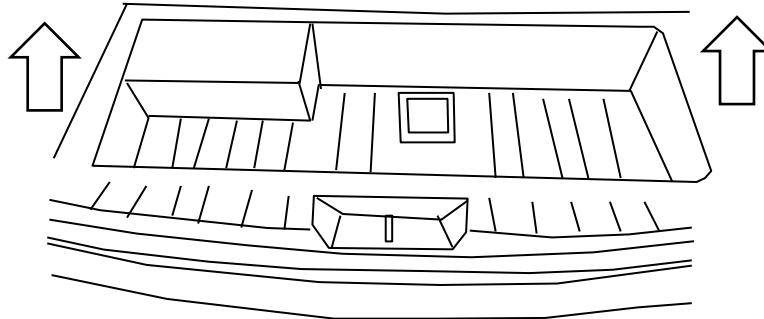

8 Remove the grommet next to the air vent at the LH rear corner of the vehicle.

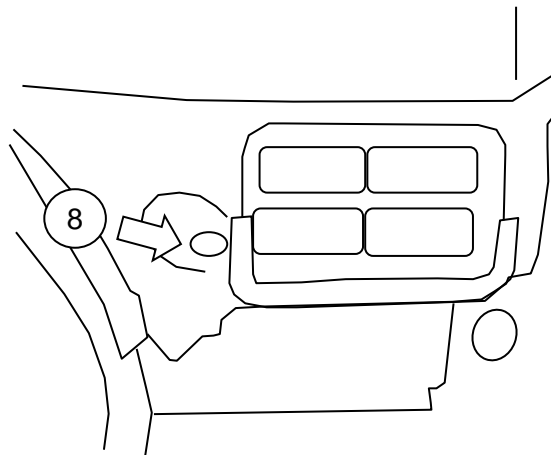
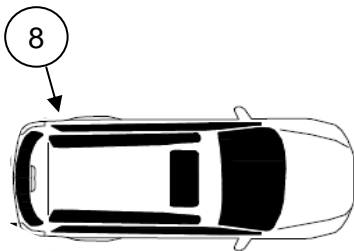

9 Continue to route the harness around the rear LH corner of the vehicle and below pressure vent. Pass the connector through the hole into the inside of the trunk well. Install the grommet into the hole.

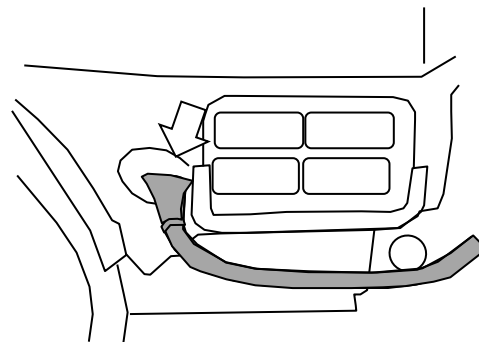
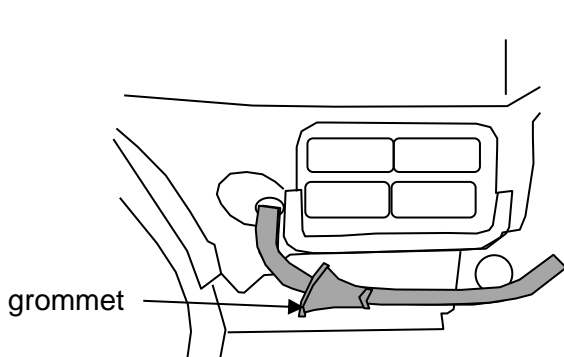

9 WIRING HARNESS INSTALLATION (CONTINUED)

- 10 Apply a cable tie mount "M" to the rear vehicle body panel in the location as shown.

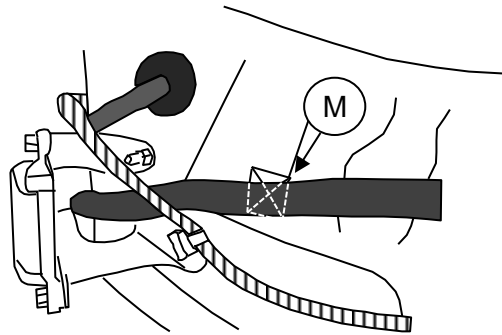

- 11 Apply 2 cable tie mounts "M" in the locations as shown

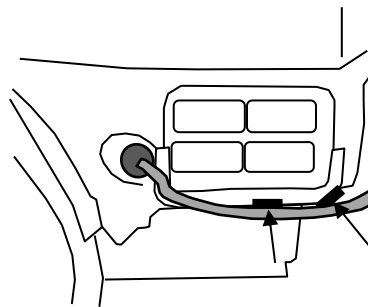

- 12 Use 5 cable ties "L" to secure the wiring harness to the cable tie mounts "M" from steps 9-5, 9-10, and 9-11.

- 13 Inside the rear trunk well, locate the vehicle side hitch harness connector.

- 14 Plug one end of the tow hitch wiring harness "I" into the vehicle side connector. Wrap the connector with 1 piece of foam tape "J". Loop the mated connector back onto itself and secure to existing trunk wiring with cable tie "L".

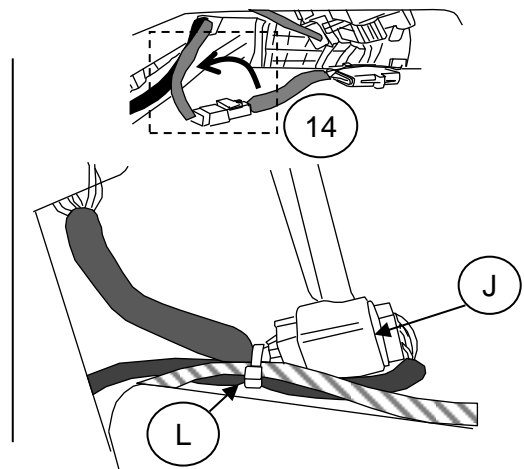
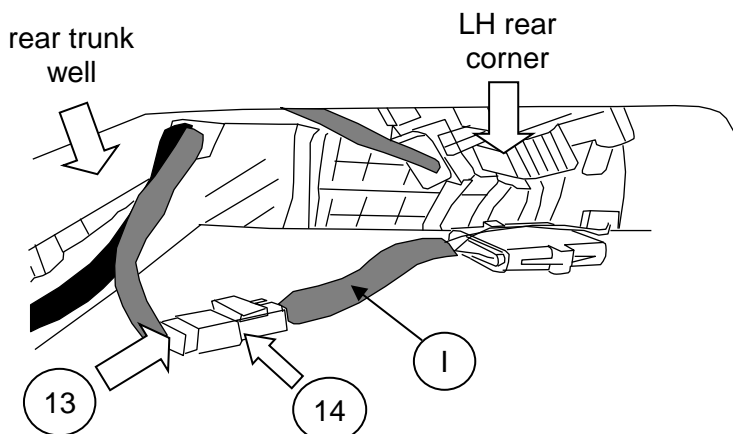

9 WIRING HARNESS INSTALLATION (CONTINUED)

- 15 From the inside of the trunk, connect the 2 ends of the trailer hitch wiring harness and wrap with a piece of foam tape "J".
- 16 Loop the excess wiring harness slack back onto itself and use a cable tie "L" to secure it to the hole in the body panel bracket in front of the grill panel.
- 17 Prepare the area in the trunk well where the control module will be installed by using sandpaper (or scouring pad) to remove the rough layer of dampening material. Once the surface is relatively smooth, remove the adhesive liner from the control module and secure it to the vehicle panel.

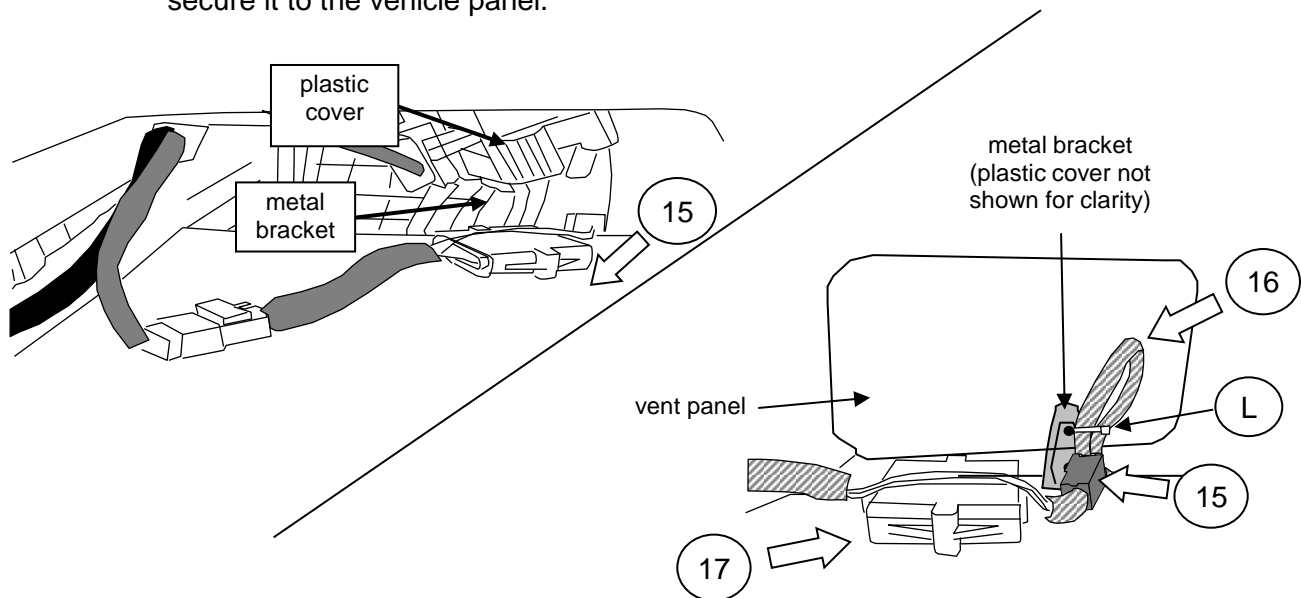

10 FASTENER "N" INSTALLATION - REMOVABLE CENTER COVER

- 1 Remove the the center hitch cover panel from the bumper fascia by removing (1) plastic push pins from the underside of each end. Discard the push pins.

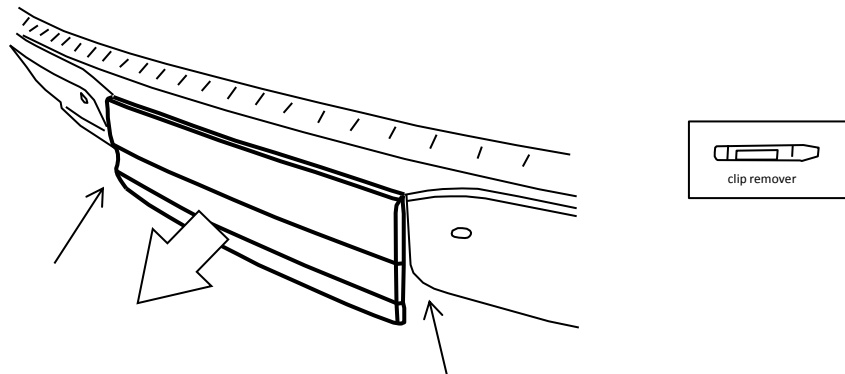

10

FASTENER "N" INSTALLATION - REMOVABLE CENTER COVER (CONT'D)

2

Remove the spring loaded tab assembly and split retaining ring from small bag. Remove and discard the 2 split retainer rings.

tab assembly

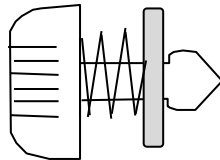

split retainer ring

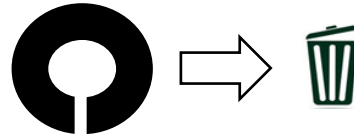

3

Install the tab assemblies into the center cover panel as shown.

tab assembly

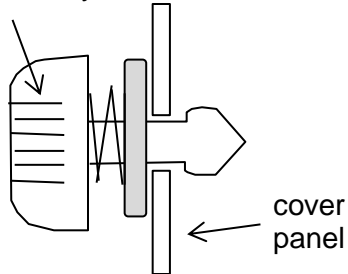

cover panel

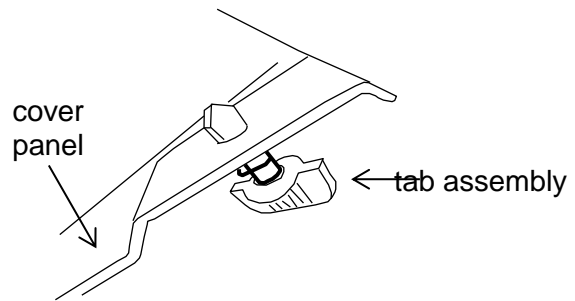

4

Install the clip-on receptacle onto the main bumper fascia.

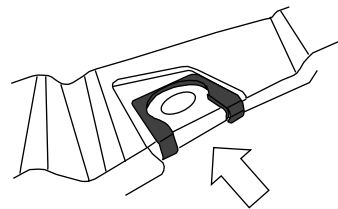
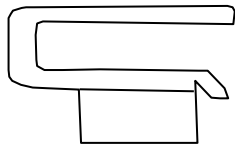

5

Reinstall the center cover panel onto the main bumper fascia. Turn the tab 1/4 turn to lock the cover in place.

11 SAFETY CHAIN HOOK

- 1 Always use safety chains when towing.

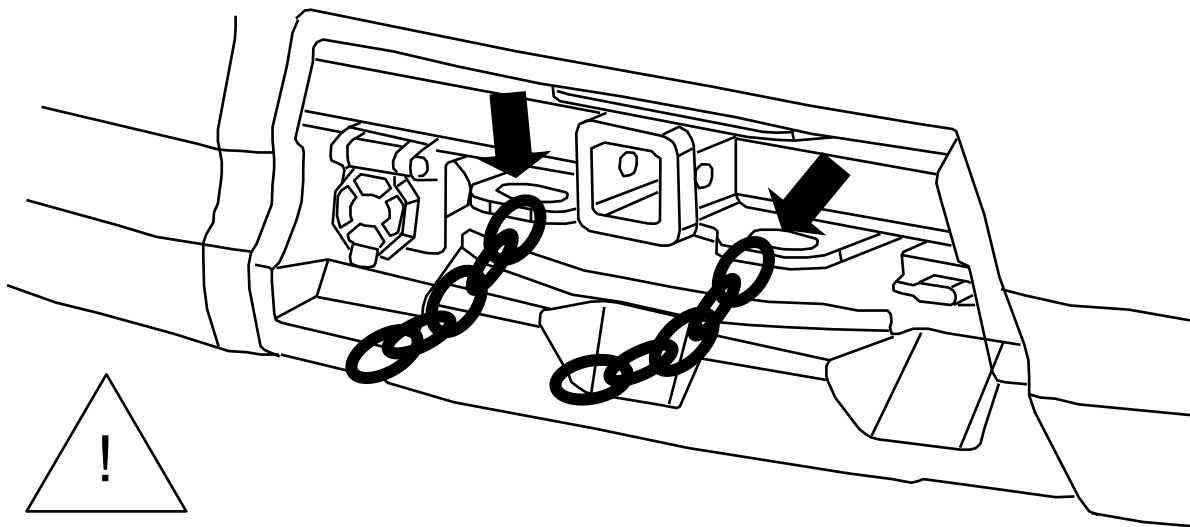

12 INSTALLATION INSTRUCTIONS

- 1 These instructions are an official document and an integral part of the trailer hitch. It should be stored in a glove box all the time and handed over with the vehicle if sold.

13 REINSTALLATION OF COMPONENTS

- 1 Reconnect RAB harness
- 2 Reinstall rear bumper fascia.
- 3 Reinstall rear tail light covers.
- 4 Reinstall spare tire and related components.
- 5 Replace rear compartment cover.

14 CAUTION



- 1 For further information, read vehicle's owners manual or consult your dealer or dealer's service department.
- 2 SUBARU accepts no liability for product defects caused by the vehicle owner or other persons and/or incorrect use.
- 3 After the first 600 miles, please consult with SUBARU dealer to re-check the tightness of Trailer Hitch bolts and/or nuts.
- 4 For models equipped with BSD (Blind Spot Detection) and RCTA (Rear Cross Traffic Alert) driving support systems, when towing a trailer, press BSD/RCTA OFF switch to deactivate the systems. The system may not operate properly due to the blocked radar waves. For details about BSD/RCTA OFF switch, refer to the owners manual "BSD/RCTA OFF switch".
- 5 For models equipped with RAB (Reverse Automatic Braking) system, please consult with SUBARU dealer when towing a trailer.
- 6 Do not exceed 16 Amp for trailer brake circuit.
- 7 Refer to table below for towing capacity.

MODEL	MAX Tow Rating	MAX Tongue Weight
Base	2000 lbs.	200 lbs.
Premium, Limited, Touring	5000 lbs.	500 lbs.

Consult owner's manual for recommended towing procedures.